

Fiberglass Tank Installation

Instructions for Installing Injection-Molded FRP Tanks

Before You Begin

To function properly, septic tanks must be correctly installed. Read these instructions all the way through before installing the tank.

Determine the depth of excavation needed. The depth of excavation depends on three factors:

- The type of soil. It may be necessary to overexcavate and fill the bottom of the hole with gravel or concrete to replace rocky or unstable soil (see Step 1).
- The depth needed to achieve the required slope for the building sewer (see Step 2).
- The depth needed to have enough soil or fill material on top of the tank to counteract the tank's buoyancy, if high groundwater conditions are likely (see "Determine whether an antibuoyancy collar is needed," below).

CAUTION: Do not set the top of the tank deeper than 48 in. (1220 mm) or shallower than the minimum depth of 12 in. (305 mm) without written authorization from the manufacturer. If a tank must be set shallower than 12 in. (305 mm), contact Orenco for special instructions.

Determine the type of fill material needed. You will need granular material for backfilling around the tank. You may use sand for bedding the tank, but **do not use sand for backfilling**. Use half-inch (13-mm) or smaller crushed rock or pea gravel for backfilling up to the tank's midseam flange. Above the midseam, you can use the same material, or you can use native soil, provided that it is free of objects that could damage the tank, such as stones larger than 2.5 in. (64 mm). Flowable concrete is also suitable.

Determine whether an antibuoyancy collar is needed. If groundwater is present or if there is any other condition that is likely to cause the tank to become buoyant, you may need to pour a reinforced concrete collar around the tank as supplemental ballast. If the backfill material used is cohesive,* no supplemental ballast should be necessary. If the backfill material used is noncohesive,** no supplemental ballast is necessary as long as your minimum depth of bury is 2.60 ft (31 in., 792 mm) for 1500-gal. (5678-L) tanks or 2.75 ft (33 in., 838 mm) for 1000-gal. (3785-L) tanks. For tanks set more shallowly, you'll need to add a concrete collar (see Step 6). Attaching an AdvanTex[®] AX20 pod to the tank with the optional saddle increases the tank's net buoyancy. Consult the Fiberglass Tank Saddle Instructions (NIN-SAD-1) to determine whether you will need an antibuoyancy collar.

NOTES: 1) Placement of these tanks in an area that receives traffic requires installation of an engineered traffic-bearing pad. 2) Orenco FRP Tanks have not been tested for use with potable water.

Step 1: Excavation

Excavate at least 24 in. (610 mm) beyond all sides of the tank, to allow room for proper compaction of the backfill. (Refer to table below.)

Tank Dimensions	1000 gal. (3785 L)	1500 gal. (5678 L)
Length	123 in. (3120 mm)	169 in. (4290 mm)
Width	72 in. (1830 mm)	72 in. (1830 mm)
Height	64.5 in. (1640 mm)	64.5 in. (1640 mm)
Approximate weight	350 lb (159 kg)	500 lb (227 kg)

If the base soil is unstable (for example, peat, quicksand, muck, landfill, or very soft or highly expansive clay), the site should be overexcavated in width and depth and a firm, compacted base of 1/2-in. to 3/4-in. (13- to 19-

*As described in OSHA Standards (29 CFR, Part 1926, Subpart P, Appendix A), cohesive soils include clayey silt, sandy clay, silty clay, clay, and organic clay. Cohesive soil does not crumble, can be excavated with vertical sideslopes, is hard to break up when dry, and when moist, can be rolled into threads without crumbling. For example, if at least a 2-in. (51-mm) length of 1/8-in. (3-mm) thread can be held on one end without tearing, the soil is cohesive.

**Noncohesive soils or granular soils include gravel, sand, or silt with little or no clay content. Granular soil cannot be molded when moist and crumbles easily when dry.

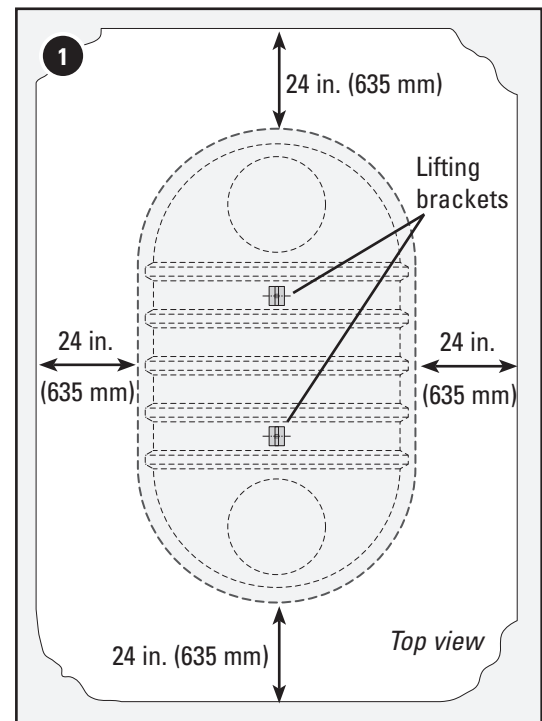

Installation Instructions (continued)

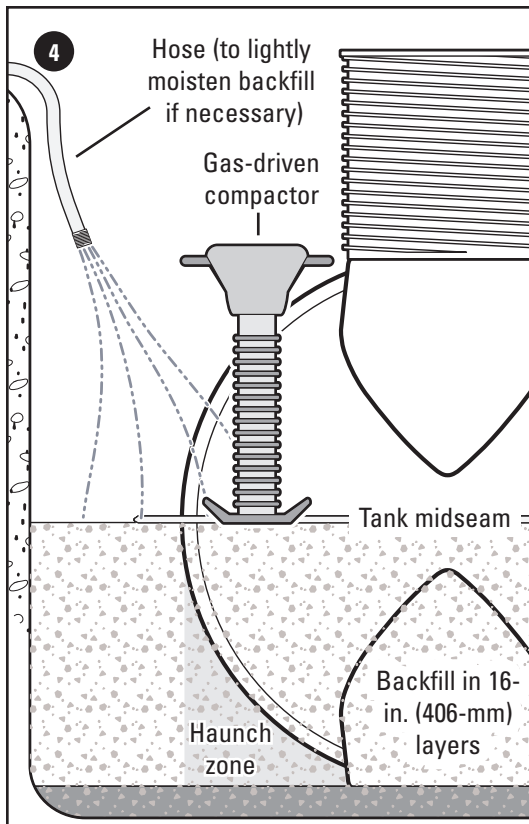
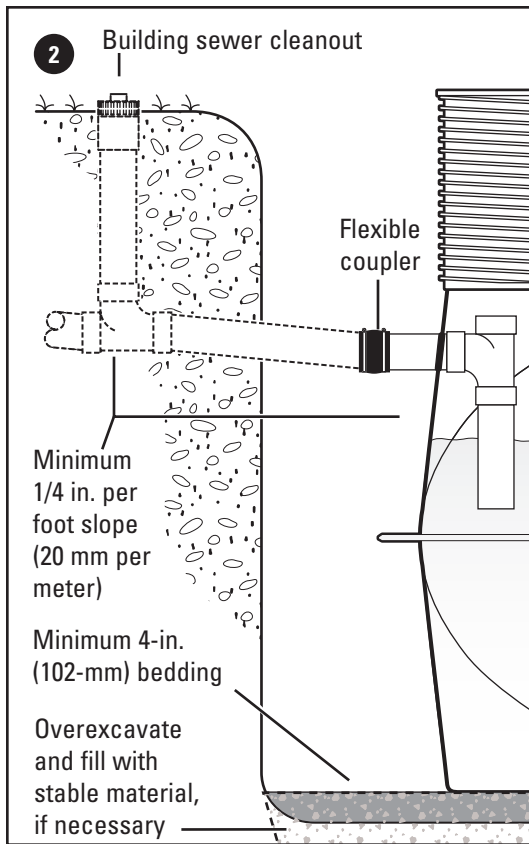

mm) crushed rock should be set before the sand or pea gravel bedding is placed. In extreme conditions, a concrete layer may be needed to stabilize the bottom of the excavation. If you have any doubt about the soil's ability to support the tank, consult a local civil or structural engineer.

Step 2: Bedding

After excavating the hole, prepare the bedding for the tank. Set the tank on a layer at least 4 in. (102 mm) thick of compacted sand, pea gravel, or other granular material less than 3/8 in. (10 mm) in diameter overlying a firm, compacted, and uniform base. Do not set the tank directly on boulders or rock edges, which can damage fully loaded tanks.

If sand bedding is used, lightly moisten the sand to compact it, but do not saturate it, or the underlying soil may become unstable.

Tanks should be placed deep enough to facilitate a minimum 1/4 in. per foot (20 mm per meter) slope of the building sewer. In some instances, buildings may have more than one building sewer. Be sure to establish the tank elevation such that a minimum 1/4 in. per foot (20 mm per meter) slope is attainable from any building sewer.

Step 3: Tank Placement

Using properly sized lifting equipment, attach a chain or cable to the two lifting brackets on the top of the tank and carefully lift the tank.

Slowly lower the tank into the excavation so that it sets into place without shifting.

CAUTION: Do not allow workers to stand within — or too close to the edge of — the excavation while placing the tank.

Set the tank level and to a uniform bearing on the compacted bedding and remove the chain/cable.

Step 4: Partial Backfill

Backfilling is a three-step process that involves adding water to the tank, placing the backfill material, and compacting the material. Backfill material should have a uniform gradation and be free of large stones. Half-inch (13-mm) or smaller crushed rock or pea gravel is required. **Do not use sand.** Each backfill layer should be uniform and of nearly equal height around the entire perimeter of the tank. If you use flowable concrete material instead of granular material, the layering and compacting steps are not necessary.

Note: Do not backfill above the midseam flange before completing the tank's watertightness test.

Begin by filling the tank about 16 in. (406 mm) deep with water to support it from within and settle it down into the bedding. Next, place a 16-in. (406-mm) layer of backfill. Using a mechanical compactor, thoroughly compact the fill, especially in the haunch zone, to minimize settlement and to provide support for the tank walls.

After the first layer of backfill is compacted, fill the tank with water to the midseam flange, add another 16-in. (406-mm) layer of backfill, and compact it so that the backfill level is slightly below the midseam flange.

Installation Instructions (continued)

Step 5: Watertightness Testing

After backfilling around the tank to the midseam flange, completely fill the tank with water, to a level 2 in. (51 mm) into the risers. You will need to plug the inlet (and outlet, if present) with a turned-up elbow or some other kind of plug. Wait at least 60 minutes (or as required by local rules) and inspect the tank for leaks. There should be no drop in liquid level and no visual leakage from seams, pinholes, or other imperfections. Once the tank is proven to be watertight, drop the water level in the tank below the invert — but not below the midseam flange.

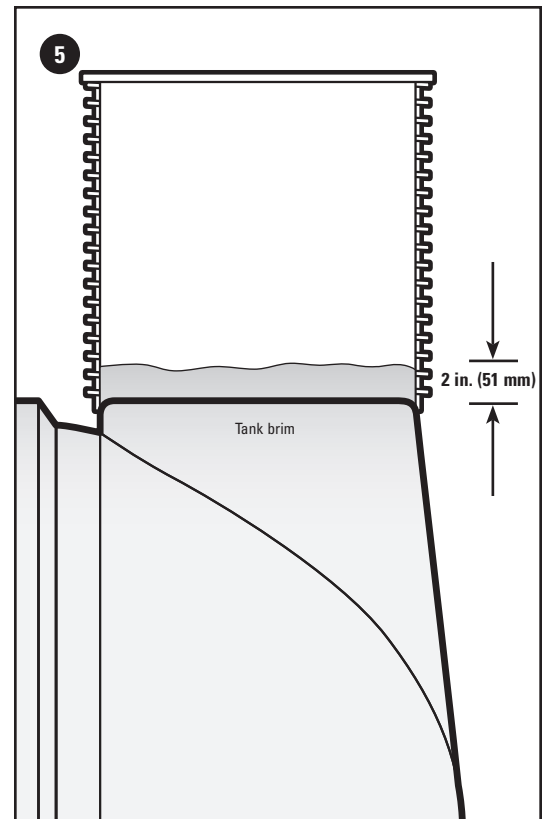

Step 6: Buoyancy Countermeasures

If groundwater is present or if there is any other condition that is likely to cause the tank to become buoyant, you may need to pour a concrete collar around the tank. Measured from the side of the tank (not the flange), the collar should be at least 18 in. wide \times 6 in. thick (457 mm wide \times 152 mm thick) with reinforcing mesh. It is the width of the collar that is important in counteracting buoyancy, not its weight. A collar of this size will be sufficient to counteract buoyancy even if there is groundwater to grade. Plan on ordering at least two cubic yards (1.5 m³) of concrete. The minimum concrete compressive strength should be 2500 psi (17.23 MPa).

There is more than one way to do this. We recommend the following:

Step 6a: Pour an 18 in. wide by 3 in. thick (457 mm \times 76 mm) lift of concrete above the entire perimeter of the 5-in. (127-mm) midseam flange, as shown. You can form a dam with the backfill to confine the concrete to the proper width.

Step 6b: Place a 12-in. (305 mm) width of remesh (6 \times 6 - 10/10 WWF or 6 \times 6 - W1.4 \times 1.4 [152 \times 152 MW9.1/9.1]) continuously around the perimeter of the tank, on top of the pour.

Step 6c: Pour another 18 in. wide by 3 in. thick (457 mm \times 76 mm) lift of concrete on top of the remesh.

If desired, instead of using the remesh, you can pour a single 18 in. wide by 12 in. thick (457 mm \times 304 mm) lift of concrete.

Allow concrete to set as long as possible — but a minimum of two hours — so that it's hard enough for the final backfill.

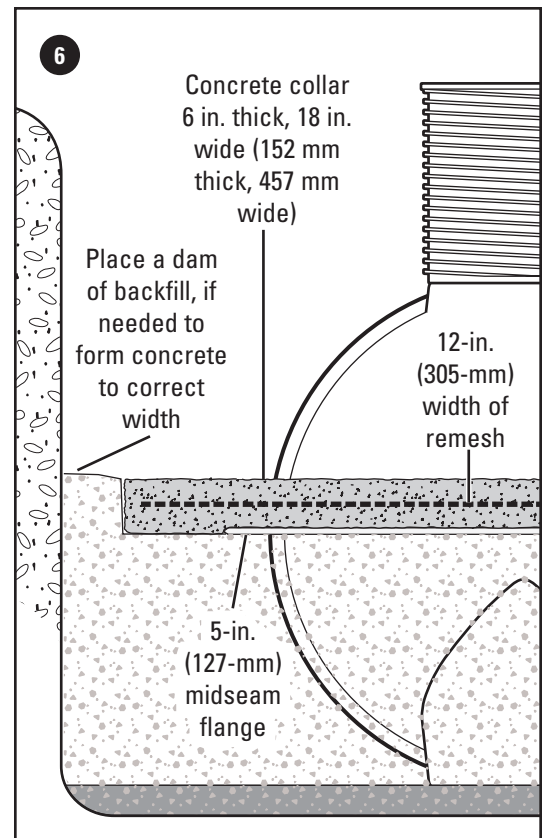

Installation Instructions (continued)

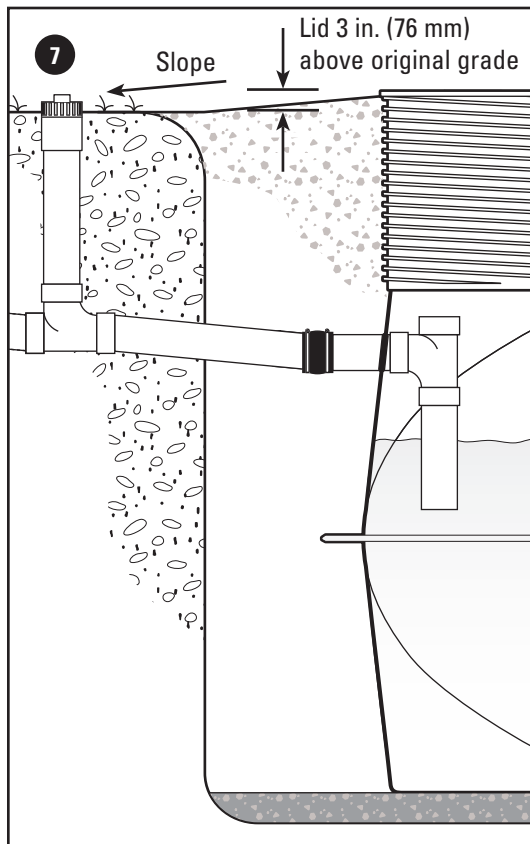

Step 7: Final Backfill and Grading

Complete the remaining backfill and compaction — above the midseam flange to the finish grade — in maximum 24-in. (610-mm) layers. Place the backfill material gently if you poured a concrete collar that day.

Flowable concrete material may be used above the midseam for backfill, as can native soil if it does not contain rocks, as described in Step 4. Backfill and compact around the inlet and outlet fittings by hand.

Make sure the risers extend a minimum of 3 in. (76 mm) above the original grade to allow for settling and to ensure drainage away from the risers.

Safety Guidelines

Follow these safety guidelines when installing your Orenco fiberglass tank:

- Most tank delivery vehicles must be maneuvered to within about 6 ft (2 m) of the hole. Position delivery vehicle so trees, buildings, etc., will not interfere with the boom. Check for low-hanging wires.
- Look for and work carefully around mud, soft spots, steep grades, or tight corners.
- Do not stand in the hole while the tank is being placed.
- When working in excavations, comply with OSHA's Standard 29 CFR, Part 1926: Safety & Health Regulations for Construction.
- Watch for water coming into the hole and side walls sloughing off into the hole.
- Stay away from the edge of the hole and watch the equipment operator.
- Check for proper alignment between the inlet pipe and the tank inlet.
- Make sure the inlet and outlet pipes have a compacted base under them to ensure proper support.
- Never leave an unattended tank without fastening lids to all access openings securely.